

HOW TO CREATE A PRINT-READY FILE :

PRESENTATION FOLDERS

The following instructions will help you create a print-ready file. If after reading them you are still unsure about anything, please visit the [FAQ](#) section of our website, request a professional File Check or contact customer support.

1 FILE FORMAT

Send your file in PDF **format in 1:1 scale (not password protected)**.

2 TEMPLATE

Always download **the template** for the product you purchased from the website and use it as the basis for positioning your artwork: this will make it easier to create a print-ready file. Take care not to alter the dimensions of the artboard and insert your artwork. Finally, save the file as a PDF, without crop marks.

SAVE THE PDF IN HIGH QUALITY, WITHOUT DOWNSAMPLING AND KEEPING THE LAYERS SEPARATE.

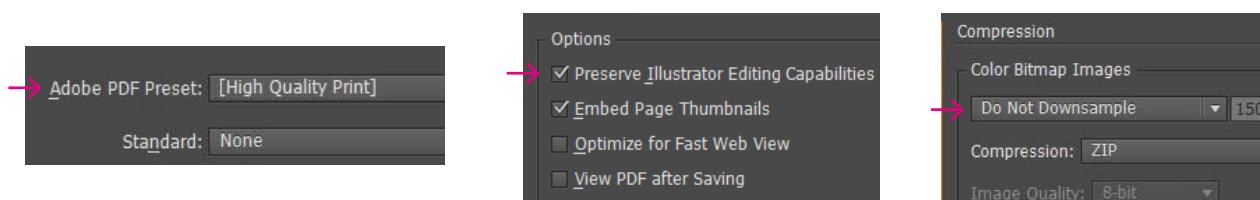

3 RESOLUTION

The optimal resolution for the print files is **300 dpi**.

4 COLOURS

All files should be sent in **CMYK** (cyan, magenta, yellow, black), with the **Fogra 39 colour profile**.

Images in RGB or with PANTONE colours will be converted automatically using a standard colour separation profile.

5 FONTS

Fonts should be **embedded in the PDF or converted into curves/paths**. The minimum font size (below which we cannot guarantee perfect print quality) is 6 pt.

6 MARGINS AND BLEED

Download the template for the product you have purchased; **the 2 mm bleed** will already be set up correctly.

Ensure that any **full bleed images** cover the entire area surrounded by the bleed line (the green line); this will avoid any unsightly white margins being left after cutting. Text should be placed at least 3 mm from the **cut line**.

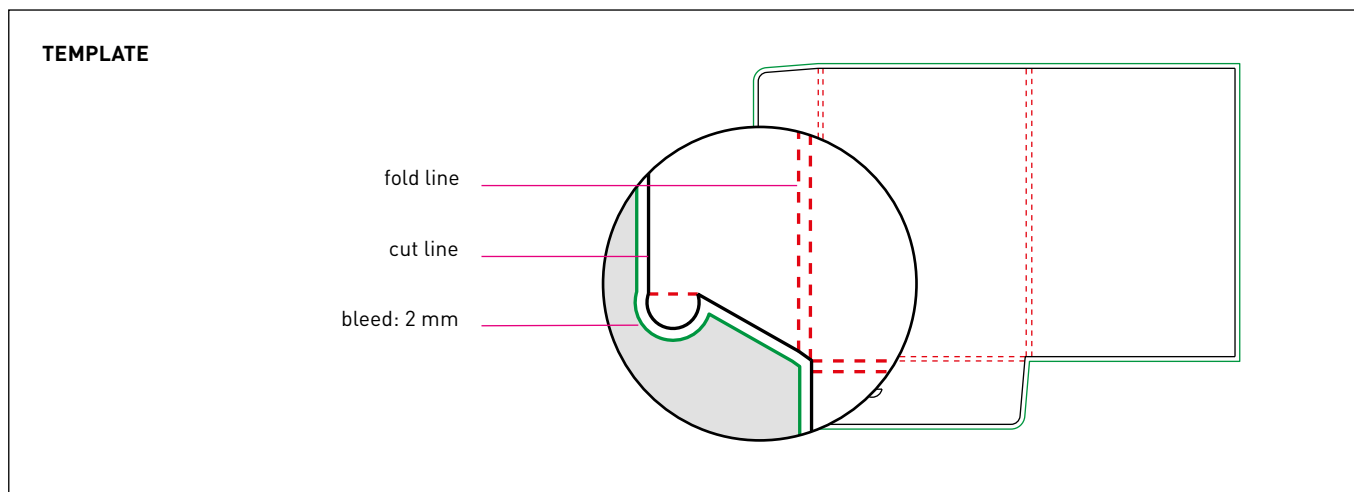

FULL BLEED IMAGES

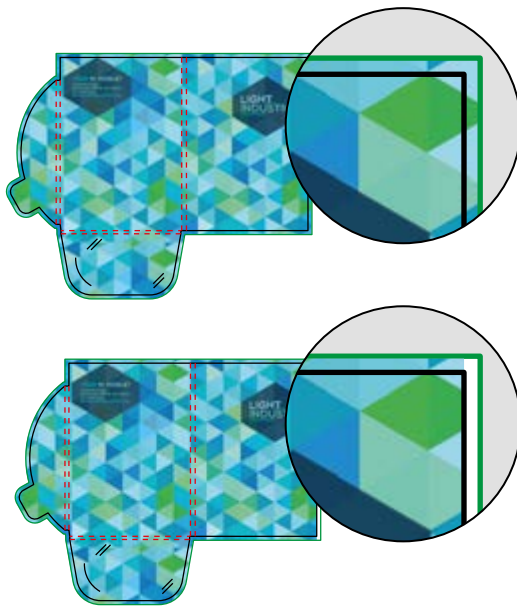

white margin

7 FINISHES

If you have chosen the **Extra-thick Varnish** or **Selective Varnish** or **Gold Coating** or **Silver Coating** options, remember that the artwork for the finish must be entered on the dedicated **Finishing layer**. The artwork on the Finishing layer must not contain gradients, halftone screens or transparency, must consist of vector graphics and must use the **Finishing colour swatch**.

You can make the finishes any shape you like, giving you more creative freedom.

The minimum font size is 10 pt, and the minimum line weight is 1 pt.

We recommend avoiding placing finishes over the scoring, to avoid the varnish or coating breaking.

The template already contains the dedicated tint, named **Finishing**. Alternatively, follow these steps to recreate the correct colour swatch.

① **LAYERS > CREATE NEW > Finishing**

Create a new layer from the **Layers** panel above the Artwork layer, and name it **Finishing**.

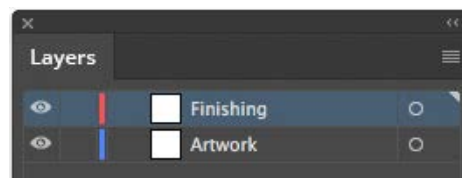

② **SWATCHES > CREATE NEW > Finishing**

Create a new colour swatch from the **Swatches** panel and name it **Finishing**; select **Spot Colour** as the Colour Type and assign the CMYK percentages 0, 50, 100, 0.

Finishing
Spot Colour
CMYK
C: 0%
M: 50%
Y: 100%
K: 0%

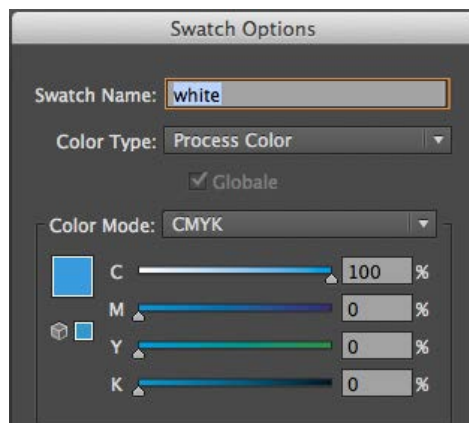

③ **FILL > Finishing**

Create a vector fill on the **Finishing** layer which corresponds to the area of the artwork to which you want to add the finish, and assign it the Finishing spot colour.

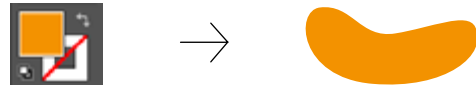

Overprint must be selected for all paths on the Finishing layer.

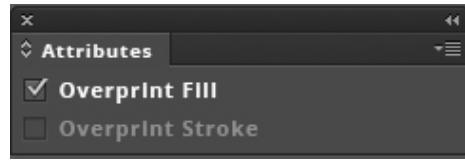

④ Save the PDF, keeping the layers separate.

⑧ **ADDITIONAL INFORMATION**

Vector paths should have a weight of at least **0.25 pt**. We **recommend that you do not place frames or passepartouts too close to the margins**, as the tolerance in the cutting process may produce a slightly uneven result.

By default, when overlapping opaque colours are printed, the top colour knocks out the area underneath. Overprinting prevents knockouts and allows the inks to overlap. To avoid unexpected colour results, **check that your file does not contain overprinted objects or text**.

NO OVERPRINTING	WITH OVERPRINTING

GOOD TO KNOW - presentation folders

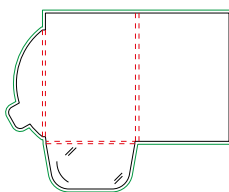

DOWNLOAD THE TEMPLATE

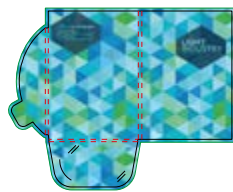

INSERT YOUR ARTWORK



SAVE THE PDF



PRINTED RESULT

✓ PDF

✓ 300 dpi

✓ 5 mm bleed

✓ CMYK

✓ FOGRA 39

✗ crop marks

GOOD TO KNOW - Four-colour printing and finish

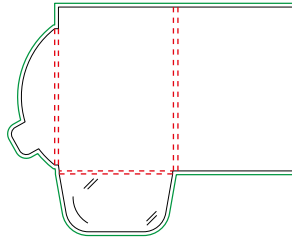

DOWNLOAD THE TEMPLATE

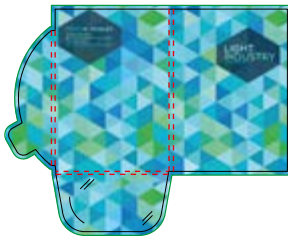

INSERT YOUR ARTWORK
on the Artwork layer

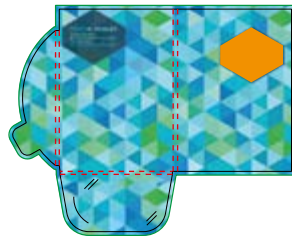

INSERT YOUR ARTWORK
on the Finishing layer

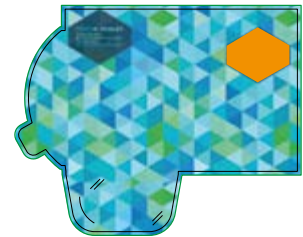

DELETE ALL GUIDELINES
except the green line



SAVE THE PDF



PRINTED RESULT

✓ PDF

✓ 250-300 dpi

✓ CMYK

✓ FOGRA 39